

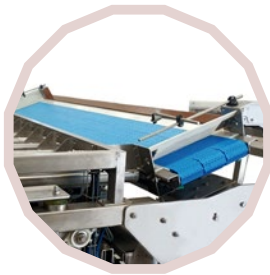

THICK/THIN WEIGHER

We have designed this solution to respond to the needs of small and large producers who seek to automate the packaging process, guarantee maximum care in product treatment, increase production capacity and optimize costs, processes and resources.

The distinctive thing about the Thick/Thin Weigher is that due to its design, it can be manufactured with 4, 8, 12 and 16 multi-heads in order to achieve the different production objectives that our clients may have.

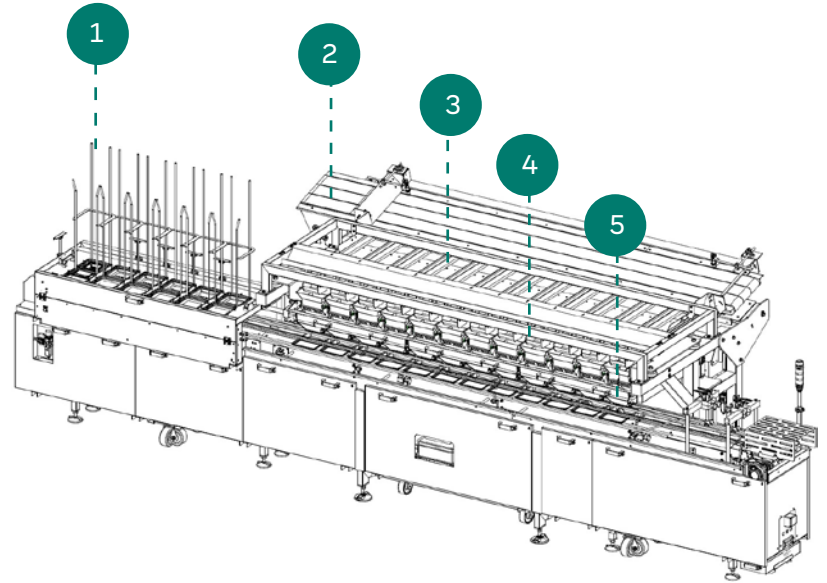

1

TRAY DENESTER X6 CHARGERS

The first element that is integrated into this packaging solution is the custom designer tray denester.

Its function is to automate the tray denesting process into the packaging machine, which in this case has 6 heads.

2

PRODUCT FEEDING CONVEYOR BELTS

At the top of the weigher, three conveyor belts that perform at different speed have the function to distribute the product until they reach the vibrating trays.

3

VIBRANT TRAYS AND THE THICK AND THIN CHANNELS

The weigher in this case has 12 trays that have the function of transporting the products to the weighing and filling hopper using a vibration system that is regulated from the intuitive configuration software.

Each tray also has two channels: one thick and one thin.

4

WEIGHING AND FILLING HOPPER

The vibrating trays feed the hopper through both channels until the target weight is almost reached. When this happens, a small pot - located at the edge of the vibrating trays - closes, leaving only the product to pass through the thin channel with the aim of adjusting the precision in the target weight per tray.

5

PRODUCT FILLING X 12

Once the precise target weight per tray is reached, the weighing and filling hoppers release the product, reducing the drop and guaranteeing easy change between packaging formats due to the filling molds.

TECHNICAL INFORMATION THICK/THIN WEIGHER

- Cadence: Varies depending on the number of heads on the weigher.
- Material: Stainless Steel.
- Minimum pressure: 6 bar.
- Pneumatic consumption: 72 L/min o 90 L/min.
- Power: 5.5 KW.
- Electrical consumption: 18 Amps.
- Connection: Three-phase 3 lines + Neutral + Ground.
- Ambient temperature: 5°C a 40°C.
- Weight of the machinery: 650 kgs.

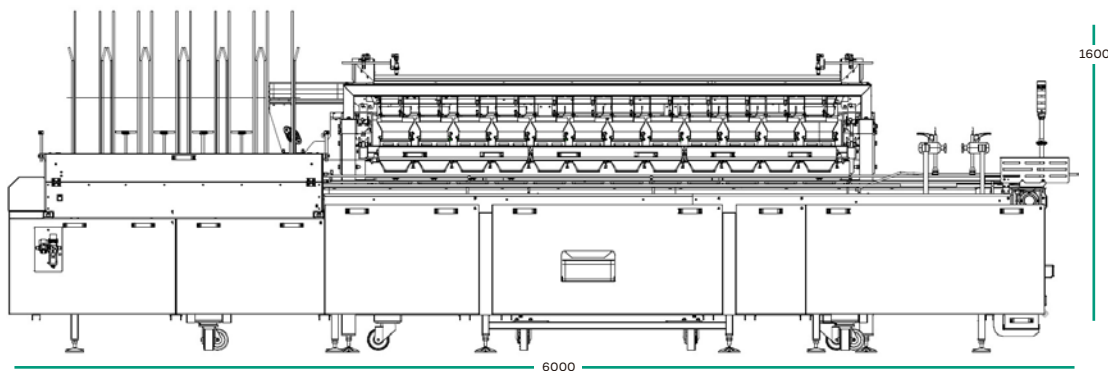
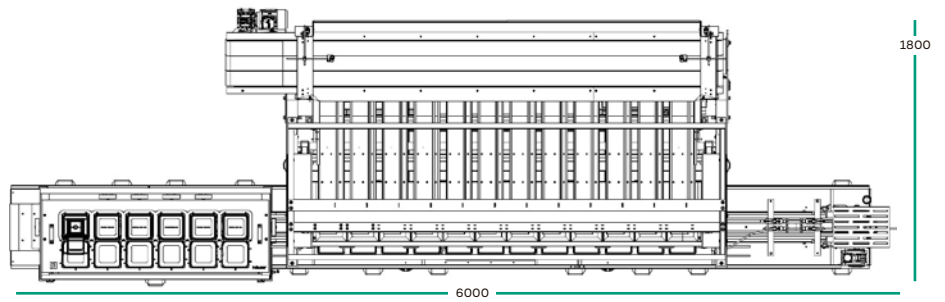

In addition to this version with 12 heads, the weigher can be designed for 4, 8 and 16 multiheads.

COMPETITIVE ADVANTAGES OF THE THICK/THIN WEIGHER

A quick solution for packaging blueberries and achieving high productions.

A design that guarantees a minimum of product drop and delicate treatment throughout the packaging process.

A precise weighing system that optimizes costs, processes and resources; and that responds to multifomat.

As with other INDUSER machines, our specialty is designing lines from start to finish, from feeding to the integration of peripheral or end-of-line machines.

