

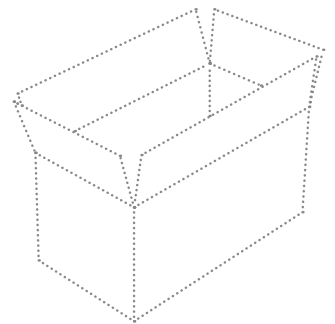

# IBS CASE ERECTOR **E21/22**



*“A stainless, flexible and compact case erector with a simple size change over.”*

**LUNDGREN** MACHINERY

– for an everyday smooth production –

# IBS CASE ERECTOR **E21/22**

## Flexible and easy to handle



The machine is of a solid design in stainless steel and erects, folds and seals corrugated board cases with hot melt or tape. It can be supplied with either right- or left hand discharge direction. It is easy to handle, require a minimum of maintenance and is easy adjustable between different case sizes. Thanks to the special parallelogram mechanism the machine can cover a wide format range despite its compact construction.

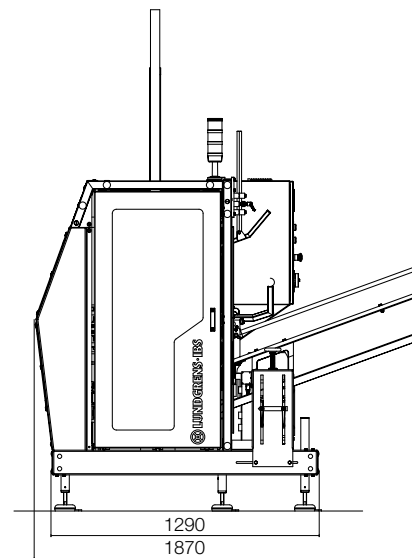
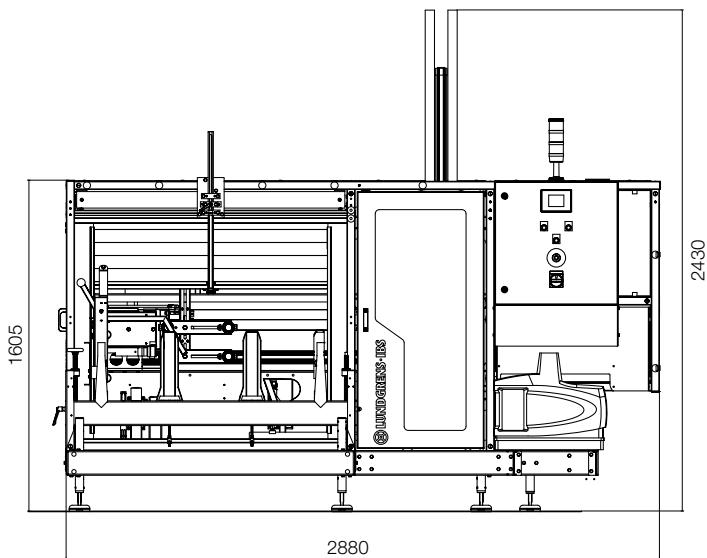

**Specifications** Air consumption: 35 l free air/case. Air connection: 1/2 inch; 600 kPa. Electrical: 3x400V AC + N + PE, 50 Hz, Fuse 16 Amps. Control: IMC.

Drive: Pneumatic or servo controlled motor. Weight: 400 kg

Maching handling arrangement

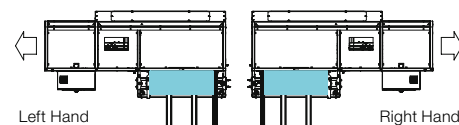

### Machine range, case sizes and capacities

Type	Hot melt	Tape	L (mm)		W (mm)		H (mm)		Cases/min
			min	max	min	max	min	max	
E21	x		200	600	150	400	100	400*	10
E21m	x		200	600	150	400	100	400*	18
E21hs	x		300	400	200	300	150	300	25
E21hp	x		300	400	200	300	150	300	30
E22		x	200	450	150	400	100	400	8
E22d		x	200	600	150	400	100	400	12
E22md		x	200	600	150	400	100	400	14

Case style: Regular slotted cases

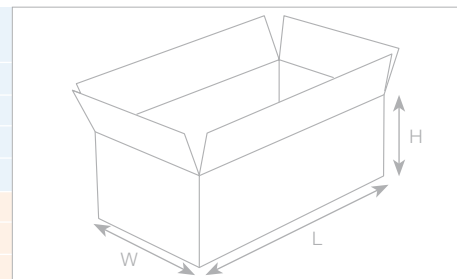

### Option

Extended magazine L = 2000 mm

\* H+ W/2 max 500 mm (standard)

## LUNDGREN MACHINERY

Lundgren Machinery AB, Box 93, SE-245 21 Staffanstorp, Sweden. Tel. +46 40 46 25 00. Fax +46 40 46 22 36.

e-mail info@lundgrenmachinery.se, www.lundgrenmachinery.se