



INDUSER

INGENUITY FOR PACKAGING

BLUEBERRIES COMPLETE PACKAGING LINE

Designing and producing high quality machinery, customized for each client's needs so they can achieve competitive advantages for the future of their businesses.



We come from "Europes's Orchard".
We are spanish.
We are from Almería.

BLUEBERRIES AND ITS JOURNEY THROUGH THE COMPLETE PACKAGING LINE.

All Induser packaging lines are customized according to the needs of each client. Multiformalt, adaptability and the delicate treatment of the product, are part of the brand promise we make.

This is the complete journey for blueberries through our solution which has a maximum capacity of production of 130 packages per minute.

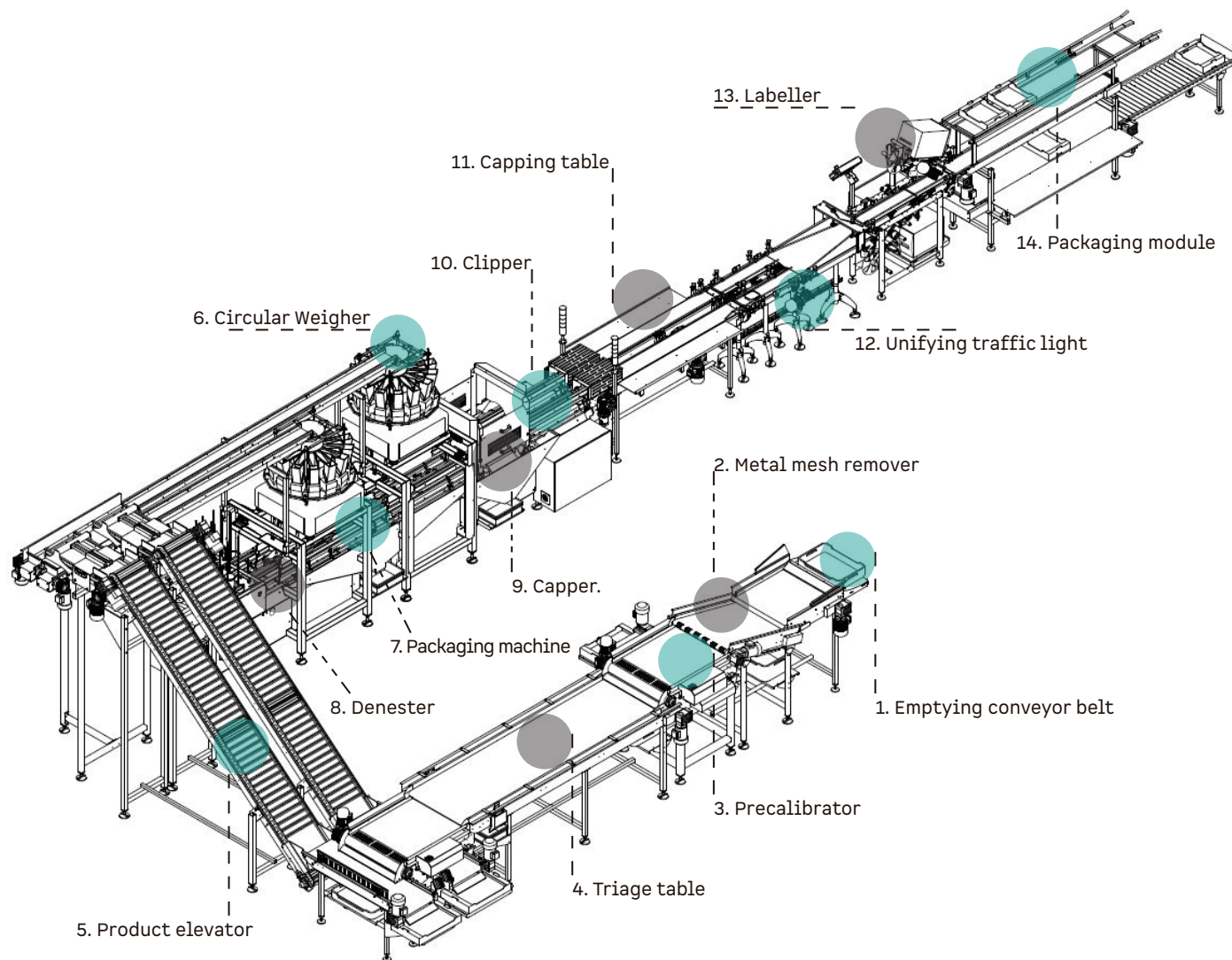

MULTIFORMAT



TRAYS



PLASTIC-FREE TRAYS



CLAMSHELLS



BUCKETS



CUPS WITH LIDS



WRAPPED TRAYS

COMPLETE PACKAGING LINE PROCESS

1. Emptying conveyor belt.

2. Metal mesh remover.

Metal mesh. Avoids the passage of tails, flowers and seeds. Free passage between meshes of 7.1mm. It includes an evacuation tray.

3. Precalibrator.

Perforated band precalibrator. It discriminates fruits of non-commercial size. Variable tria diameter; 10, 12 or 14 mm. Electric vibrator with intensity control. Tray or conveyor belt to collect the product.

4. Triage table.

Triage canvas conveyor. Double lane for evacuation of triated product. Trias collection trays. It incorporates anti-rotation product rails and avoids losing the bluberrie's "bloom".

5. Product elevator.

6. Circular Weigher.

Associative multihead weigher with 14 heads. Get clusters of blueberries with the exact weight. Weight error: +/- 1 gram. Accumulation and weighing hoppers of 0.5 L.

7. Packaging machine.

Packaging machine for filling trays, cups, punnets, buckets and shakers. Multi-format system. Servo- controlled conveyor. Double memory and filling hopper. Electric vibration system. Remote control.

8. Denester.

Double head dispenser. Multi-format system. Allows any type of tray to be filled. Quick format change. Alerts when lacking product.

9. Capper.

Servo- motorized rotary capping system designed to cover glasses and buckets of different sizes.

10. Clipper.

Pneumatic system that allows closing trays with a hinge or with a built-in lid. Multi-format system.

11. Capping table.

12. Unifying traffic light.

13. Labeller.

14. Packaging module.

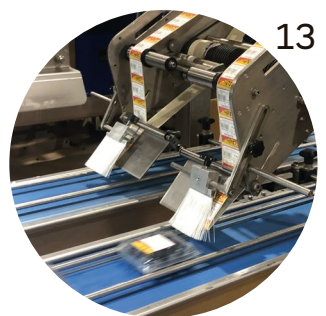
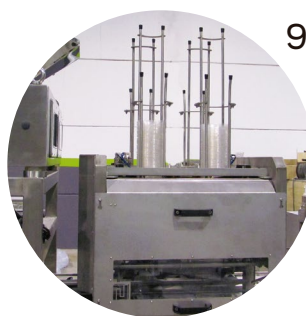
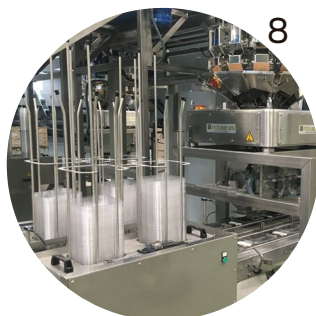
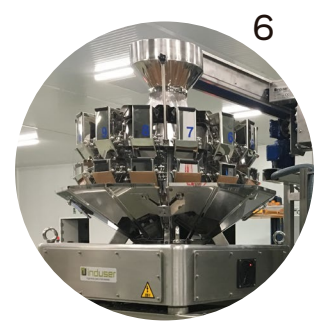
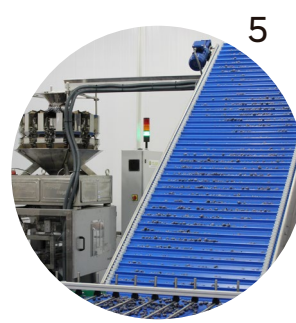
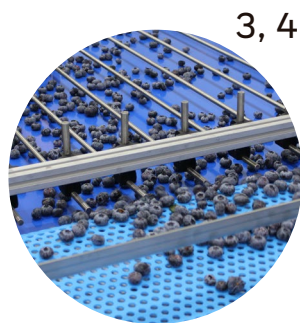
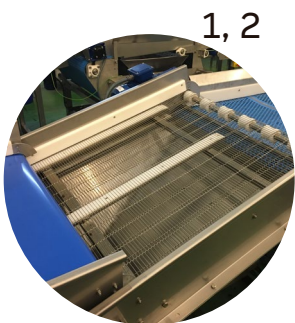

DIMENSIONS

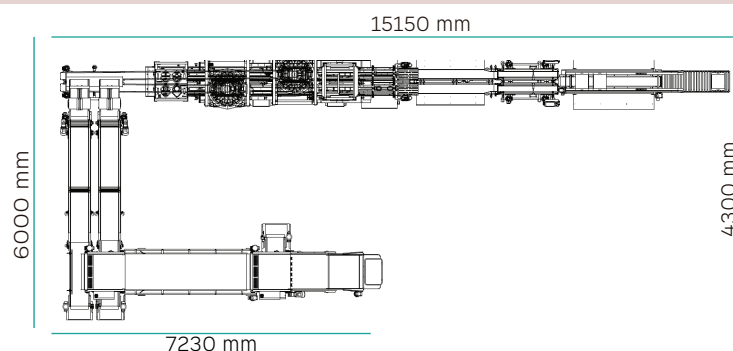

WE ARE A FAMILY SPIRIT COMPANY
WITH A PASSION FOR
INTERNATIONAL SERVICE.



www.induser.es

INDUSER

C/II Parc. 28 Polígono Industrial La Redonda CP. 04710
El Ejido, Almería, España.
Tel. +34 950 58 11 36.

