



INDUSER
INGENUITY FOR PACKAGING

BLUEBERRY PACKAGING LINE (BULKS).

Designing and producing high quality machinery, customized for each client's needs so they can achieve competitive advantages for the future of their businesses.



We come from "Europe's orchard".
We are spanish.
We are from Almería.

BLUEBERRIES AND ITS JOURNEY THROUGH THE COMPLETE PACKAGING LINE.

All INDUSER'S packaging lines are customized according to the needs of each client. Multifomat, adaptability and the delicate treatment of the product, are part of the brand promise we make.

This is the complete journey for blueberries when the packaging format is bulk crates.

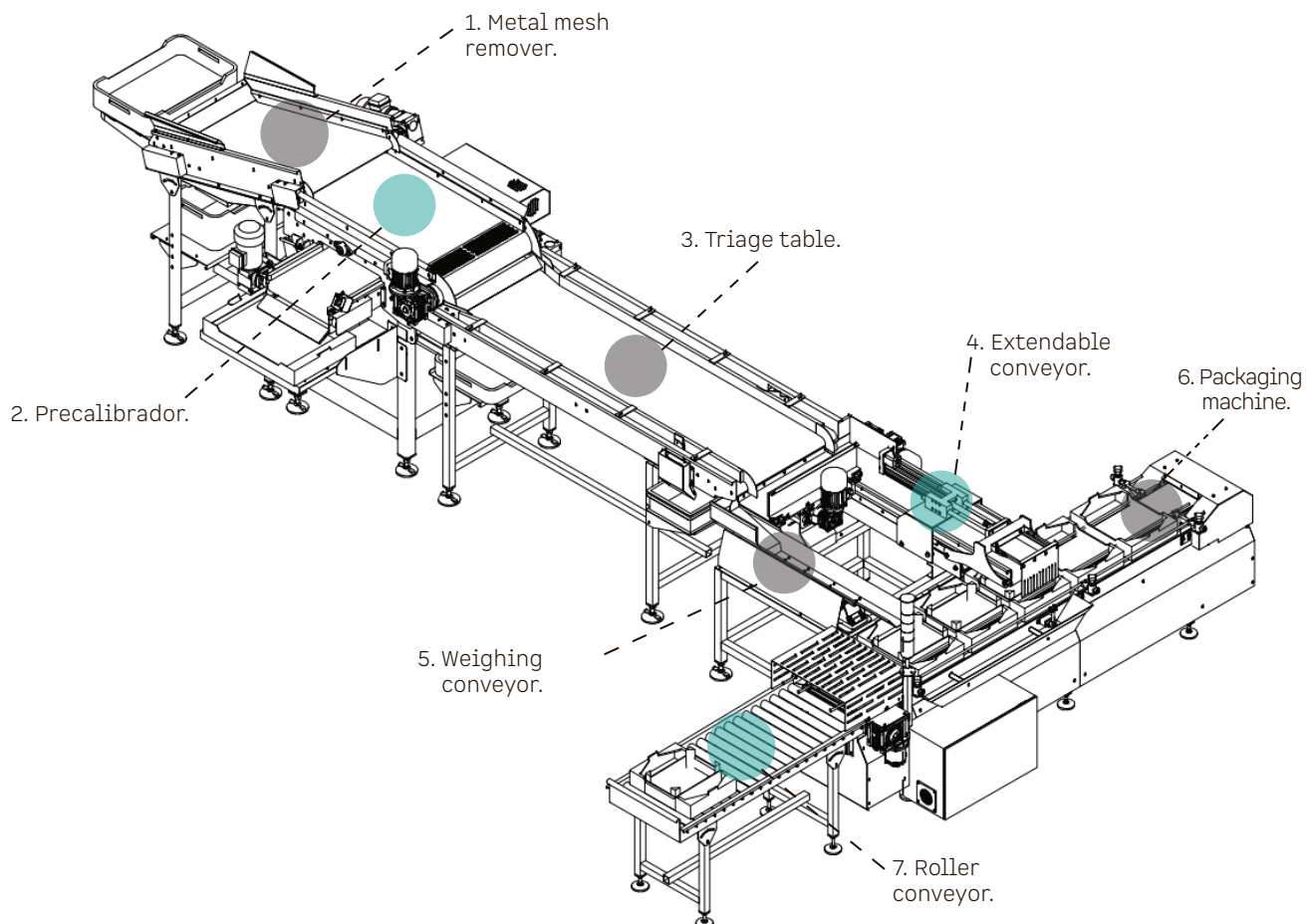

1.



2 y 3.



4.



5.

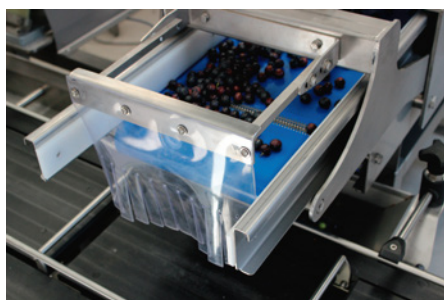

6.

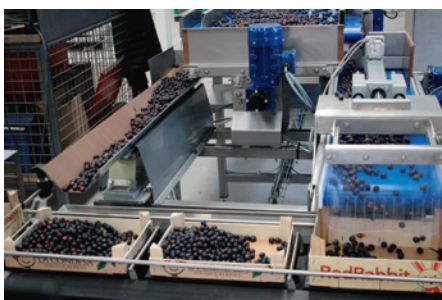

7.

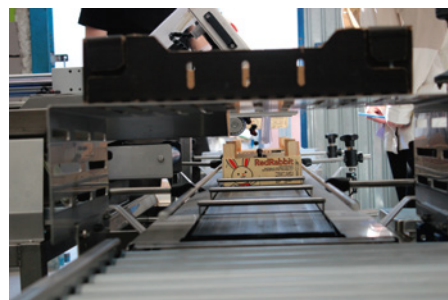

THE PACKAGING PROCESS

1. Metal mesh remover.

Metal mesh. Avoids the passage of tails, flowers and seeds. Free passage between meshes of 7.1mm. It includes evacuation tray.

2. Precalibrador de banda perforada.

Perforated band precalibrator. It discriminates fruits of non-commercial size. Variable tria diameter of 12 mm. It counts with an electric vibrator with intensity control. Tray or conveyor belt to collect the product.

3. Triage table.

Triage canvas conveyor. Double lane for evacuation of triated product. Trias collection trays. It incorporates anti-rotation product rails and avoids losing the blueberrie's "bloom".

4. Weighing conveyor.

Automatic distribution conveyor to the coarse and fine product feeding channles prior to the packaging machine.

5. Extendable conveyor.

It delicately feeds the packaging machine with a uniform distribution in the container (bulk box).

6. Packaging machine.

It has a double scale with independent weighing of the coarse and fine channel directly on the scale. Allows the coarse channel to be filled at the same time as the fine channel to optimize filling capacity.

7. Roller conveyor.

It serves the accumulation of already weighed boxes through gravity rollers prior to palletizing.



BULKS

This packaging line was designed for the filling of boxes with a production capacity of 900-1000 kg/hour.

DIMENSIONS

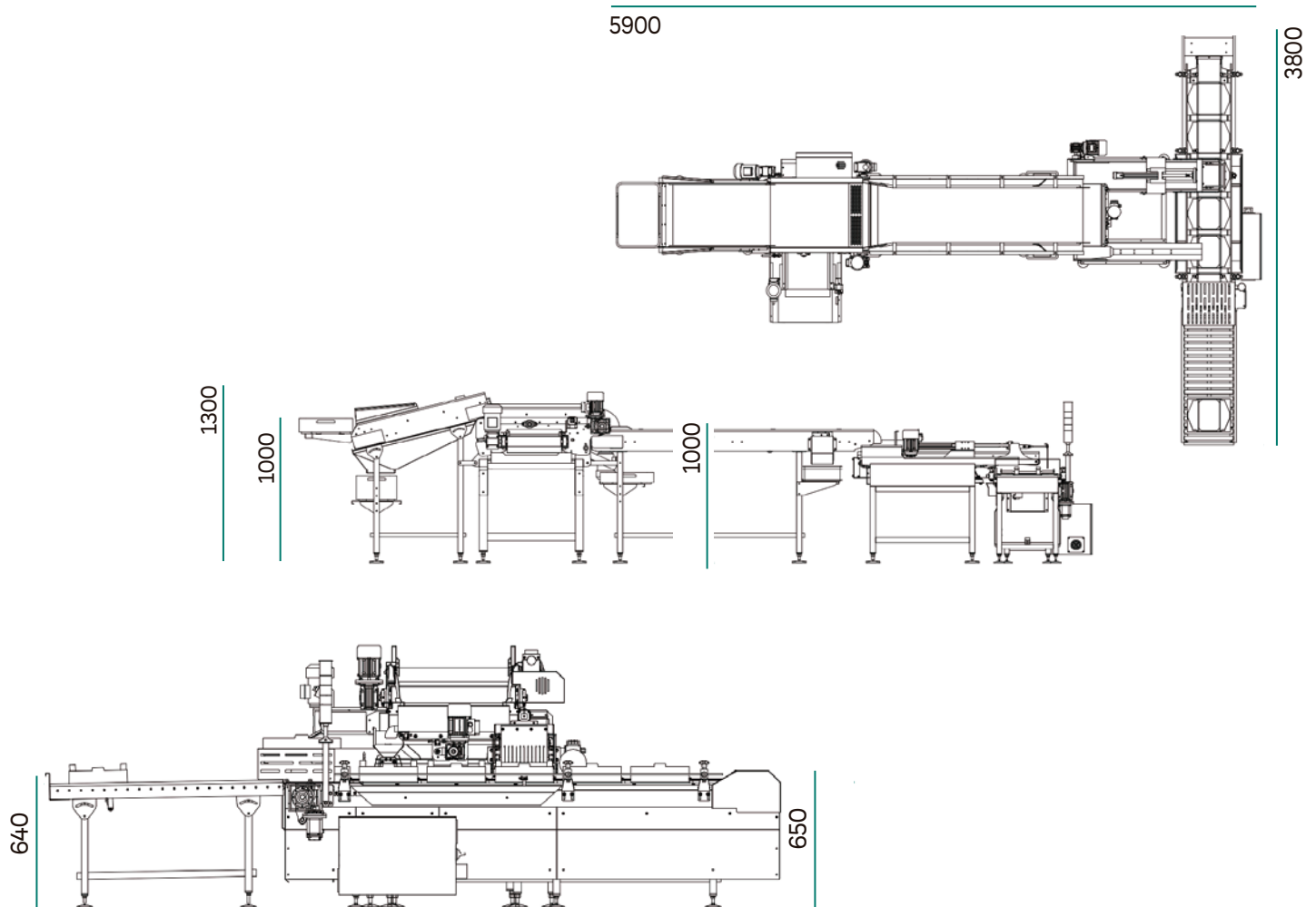

WE ARE A FAMILY SPIRIT COMPANY
WITH A PASSION FOR
INTERNATIONAL SERVICE.



www.induser.es

INDUSER

C/II Parc. 28 Polígono Industrial La Redonda CP. 04710
El Ejido, Almería, España.
Tel. +34 950 58 11 36.

