

Reisopack[®]

Compression strapper for
Vertical strapping with top seal

2210

Strapping technologies

**Effective pallet volume reduction
to improve transport
and storage**



Automatic machine with press for the vertical strapping of cardboard on pallets.

- Our own in-house manufacture and technology using top quality European components.
- Aluminium head, tempered tension rollers for longer machine life.
- Adjustable tension through clip system.
- Adjustable press for packet compression up to 1,600 Kg.
- Motorized strap feed and guidance.
- Electronic control of the entire strap tensioning, sealing, cutting and ejection process.
- Incorporated selector for polypropylene and polyester strapping.
- Equipped with seal cooling timer to improve seal quality.
- Prepared for integration into fully automatic lines.
- Safety standards. CE mark.
- Double-chain press feed.
- Transportation connection hooks.

2210

Compression strapper for Vertical strapping with top seal



- Roller conveyor incorporated into the lower part of the machine

OPTIONS:

- Telescopic bayonet
- Turncross
- Closed arch and bayonet
- Press up to 3,000 Kg.



Detail of the highly durable aluminium strapping head.



The 2210 offers high performance in simultaneous strapping and pressing of cardboard on pallets.

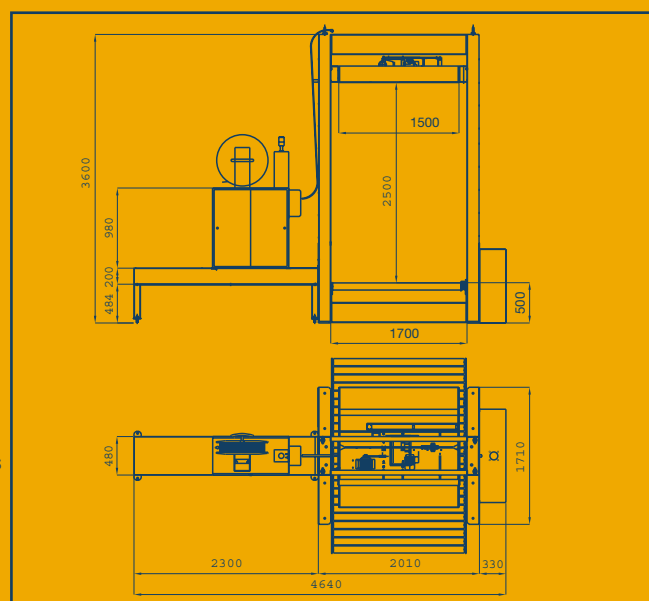

GENERAL CHARACTERISTICS

REQUIRED VOLTAGE: 220 V / 380 V · 50 / 60 Hz · 3 Phase & Neutral

CONSUMPTION: 6 Kw.

APPROX. PRODUCTION: 50-60 pallets / hour.

PACKED MACHINE DIMENSIONS: According to arch size.

TECHNICAL SPECIFICATIONS

STRAP WIDTH: 12-15.5 mm.

STRAP THICKNESS: 0.70-0.85 mm.

STRAP TYPE: Polypropylene or Polyester.

SEAL-WELDING: By electrical resistance.

Adjustable sealing temperature and cooling time.

01/04 Edition -We reserve the right to made any modification without prevention.

Reisopack s.l.

Polígono Industrial "Z"
C/ De la Prensa, 3
08150 Parets del Vallès (Spain)

Tel. 902 153 448 - Fax 935 624 186
http://www.reisopack.com
E-mail: reiso@reisopack.com