

The strapping
machine adaptable
to packaging lines



2000

Side Sealing Automatic strapping Machine

High performance automatic strapping machine. Very fast. Maximum reliability even working with 6 mm. strap.

- Own manufacture and technology using first quality components.
- Aluminium head set and tension roller treated ensures long life to the machine.
- Tension electronically adjustable through a magnetic clutch to get the strongest tension without any physical effort.
- Electronic control of the tension, heating, cutting and length of the strap.
- Especially suitable for the strap of packages higher than wide: wooden packages, aluminium, sausage boxes, etc.
- Electric adjustment of the cooling after sealing to get better sealing quality, especially for hard packages (wood, iron, etc).
- Light and easy to move because its two fixed and two revolving castors.
- Easily adaptable to packaging lines.

OPTIONS:

- Available in a lot of different dimensions of arch (from 650 mm. to 2500 mm. in width and high).
- Single phase version 220 v.
- Pneumatic press or subjection packages system.



Detail of the aluminium head set. Tension system treated to extend the life of the machine.

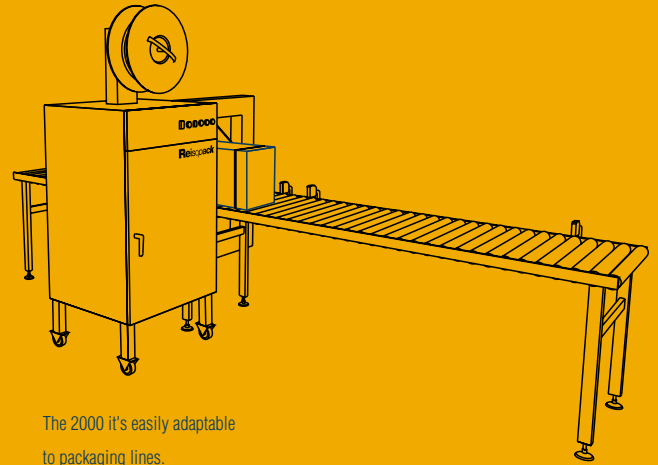

The 2000 it's easily adaptable to packaging lines.

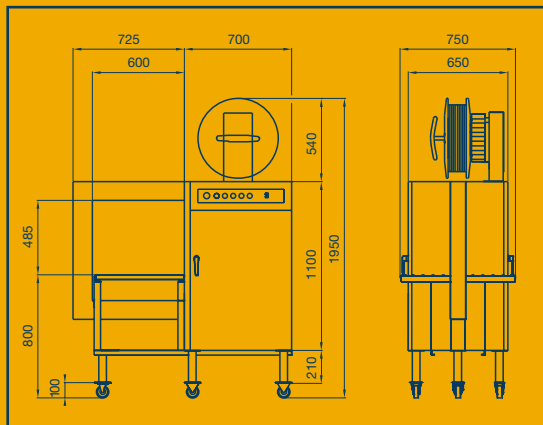

CHARACTERISTICS

VOLTAGE: 220 V / 380 V - 50 / 60 Hz. III phases.

ELECT. CONSUMPTION: 1 Kw.

APROX. PRODUCT: 30 straps / minute.

PACKAGING DIMENSIONS: 1 package (250 Kg.).

155 X 80 X 201 cm. (Standard arch 650 X 400 mm.).

TECHNICAL SPECIFICATIONS

STRAP WITH: 8-12-15,5 mm. (Must be adjusted in the factory).

STRAP THICKNESS: 0,50-0,85 mm.

HEATING SYSTEM: Electrical heating.

Heating temperature and cooling time adjustable.

01/04 Edition -We reserve the right to made any modification without prevention.

Reisopack s.l.

Polígono Industrial "Z"
C/ De la Prensa, 3
08150 Parets del Vallès (Spain)

Tel. 902 153 448 - Fax 935 624 186
<http://www.reisopack.com>
E-mail: reiso@reisopack.com